

DATASHEET

LDX Cameras Accessories



Complete your camera system with hand-held or tripod-mounted options to fit all live production needs. LDX cameras offer a variety of viewfinder options for different resolutions, brightnesses, and viewing conditions. Accessories may be interchanged within a camera series to match production needs.

LDX 90 Series Accessories

- VF 800-H 7" FHD LCD Viewfinder** 3
- EyeCatcher EC 200 2" LCD Viewfinder** 5

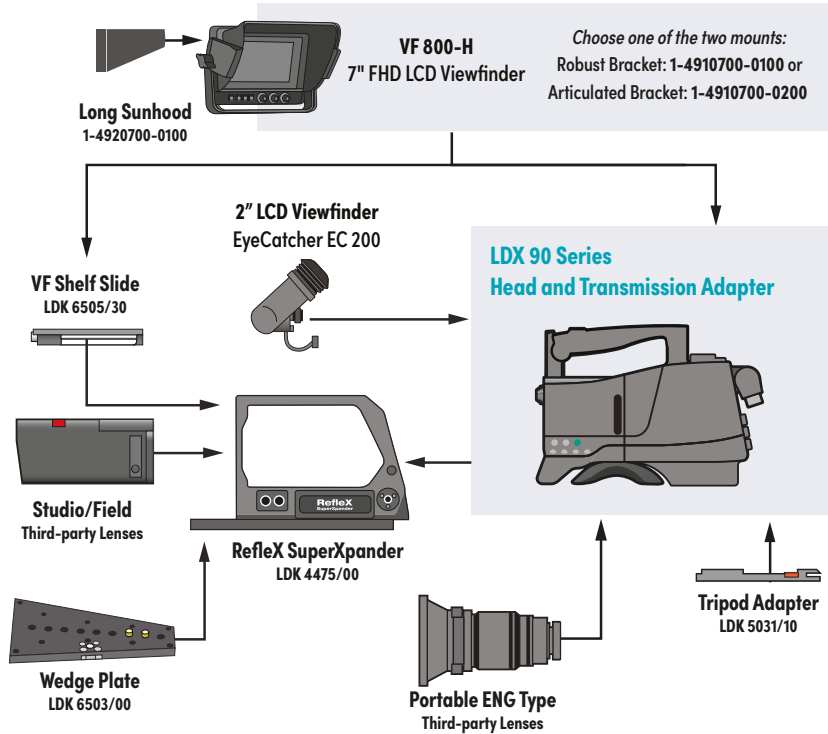

LDX 100 Series Accessories

- VF 8-100-H 7" FHD LCD Viewfinder** 6
- EyeCatcher EC 2-100 2" LCD Viewfinder** 8

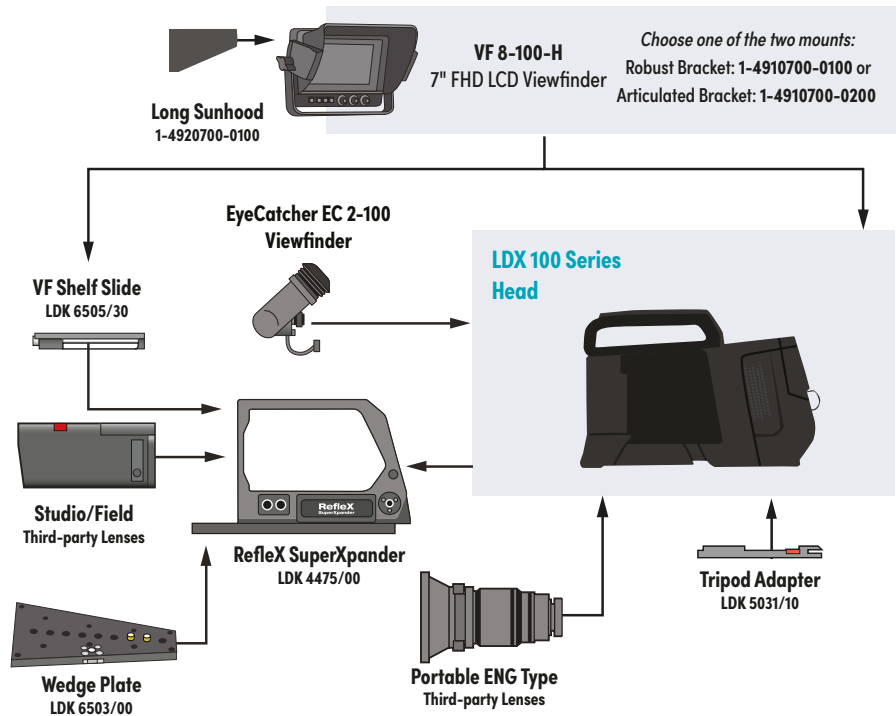

LDX 90 & LDX 100 Series Accessories

- RefleX SuperXpander** 9
- Ordering Information** 10

VF 800-H Viewfinder

The VF 800-H viewfinder for the Grass Valley LDX 90 Series cameras has native HD resolution in addition to high brightness and contrast as well as fast refresh rate, making it ideal for both indoor and outdoor use.



The VF 800-H is a compact, high-quality, flat panel color viewfinder designed to work with Grass Valley LDX 90 Series system cameras. The stylish design allows for direct mounting to the mini wedge plate of the camera head in both EFP and SuperXpander configurations.

With native HD 1920x1080 pixels, panel focusing becomes easy. In combination with high brightness and contrast, and a fast display refresh rate, the VF 800-H is the perfect color viewfinder for both indoor and outdoor applications.

The VF 800-H color viewfinder has an intuitive menu structure which not only allows for settings of the viewfinder, but can also be used to activate WFM and

Vectorscope functionality. Three rotary controls, for contrast, brightness and peaking settings, are easily accessible at the front panel.

It is possible to choose between two different mounting brackets that differ in their flexibility and adjustment range. The robust mounting bracket offers a lightweight, compact and very cost-effective solution in which the viewfinder can be rotated horizontally and swiveled up and down, but the height of the center of the screen cannot be changed. The larger and more flexible articulated mounting bracket also allows the height of the viewfinder to be adjusted, resulting in better ergonomics for the user in many applications.

Key Features

- 7-inch LCD panel with LED backlight
- High brightness and contrast
- Full HD resolution with 1920x1080 pixels
- Adjustable box and markers
- Waveform and Vectorscope can be superimposed
- Supports all current and future formats
- Supports 4K/UHD operation
- Standalone operation with SDI or HDMI interface
- Fast response time
- Easy accessible viewfinder menu via viewfinder controls
- Two different mounts to choose from, the cost effective robust mount and the more flexible articulated mount

Specifications

Connectors

Camera connectors:

20-pin Hirose
SDI input
HDMI input
DC input: XLR 4-pin

Controls

Menu button
Menu rotary
Input button
Marker button
Mono button
Power On/Off
Brightness rotary control
Contrast rotary control
Peaking rotary control

Indicators

LED indicators front:

ISO (yellow)
On-air (red)
Call (green)

LED indicators back:

On-air (red) selectable: off/low/high

General

Power consumption: 16W
Operating temperature: -20°C to +45°C (-4°F to 113°F)
Storage temperature: -25°C to +70°C (-13°F to 158°F)
Weight: 1.2 kg (2.65 lbs.) without accessories

LCD*

Diagonal size: 177.8 mm (7 in.)
Active video: 16:9 1920 (H) x 1080 (V) pixel
Viewing angle: 170° in horizontal and vertical

Performance

Color depth: 16.7 million colors
8-bit color
Brightness: 350 cd/m²
Contrast ratio: 1100:1
Color temperature: 6500K/9300K/user selectable
Pixel pitch: 0.081 x 0.081 mm
Supported formats: All current HD formats

Supplied Accessories

Short sunhood
Cabling
User's guide

* The viewfinder's LCD panel is manufactured using high-precision technology that yields a pixel response of 99.99% or higher.

Note: VF 800-H is compatible with the LDX 80 and LDX 90 Series cameras only

VF 800-H Viewfinder Dimensions

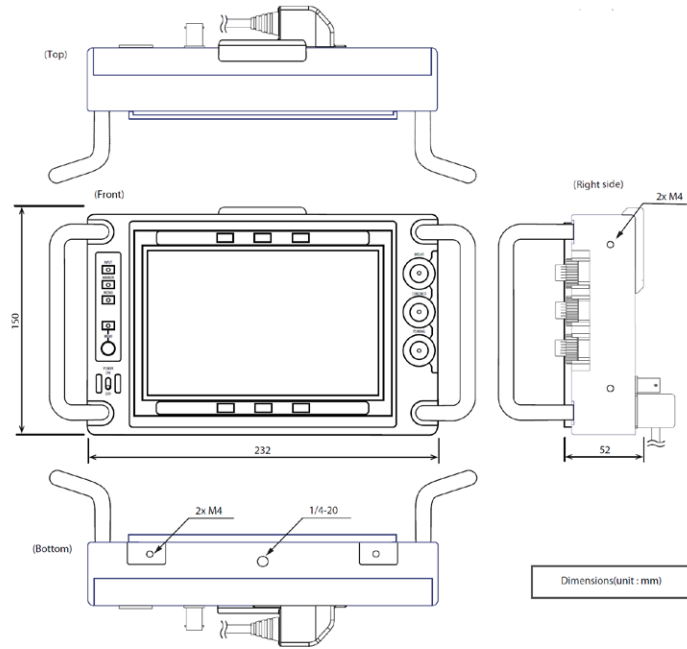

Robust Mounting Bracket

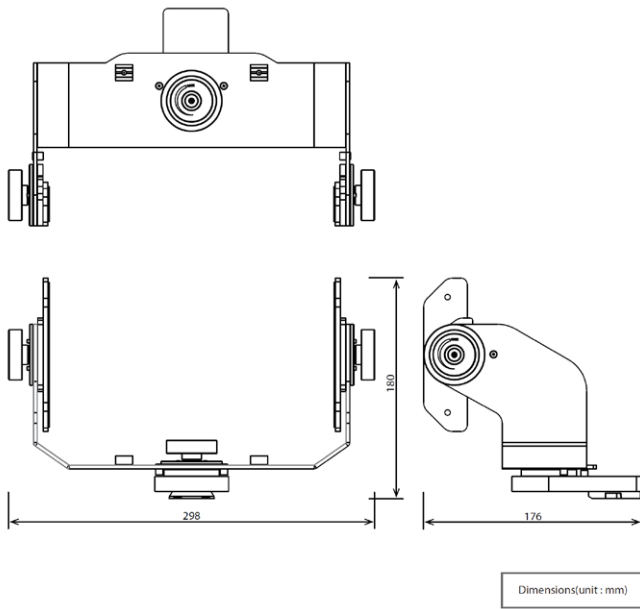

Articulated Mounting Bracket

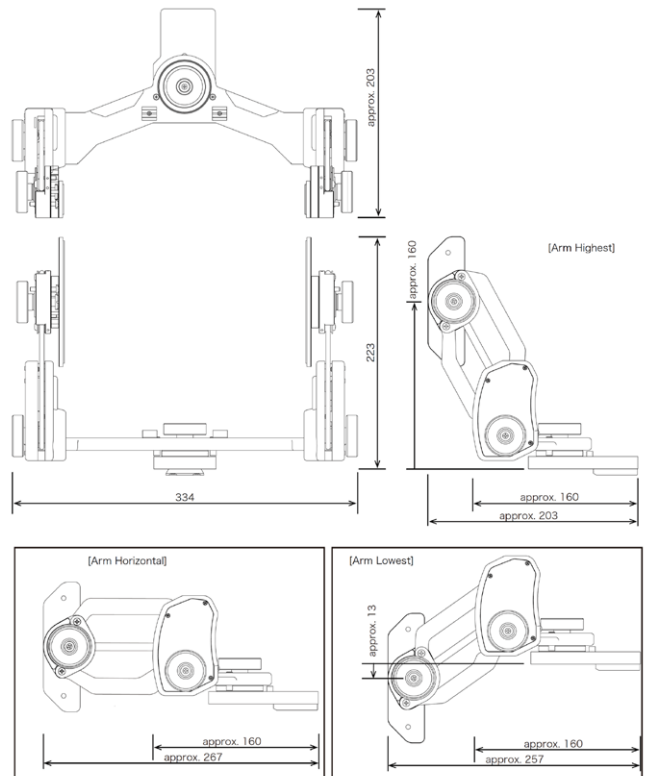

EyeCatcher EC 200 Viewfinder



The eyes are the most important tools used during a production. Every detail of a shot is important—and the operator must be able to rely on what they are seeing. The **EyeCatcher EC 200** color ocular viewfinder provides users with the confidence to know what they see is what is also being seen in the control room and by viewers.

The Grass Valley EyeCatcher EC 200 is a high performance color LCD ocular viewfinder for the LDX 90 Series camera heads. It is part of a full line of state-of-the-art color viewfinders and is very feature-rich with an intuitive user interface. The EyeCatcher viewfinder also has a stylish look and compact design.

EyeCatcher EC 200 offers the best possible image performance, high-speed response time, QHD resolution of 960x540 pixels and a diagonal size of 5.1 cm (2.0 in.). The controls are easy and flexible, similar to the Grass Valley 7-inch and 7.4-inch color LCD viewfinders. It comes with two (task) assignable user buttons and a -3 to +1 diopter compensation range.

Key Features

- Stylish look and compact design
- Fully compatible with all LDX 90 Series cameras
- Offers the best possible image performance:
 - High resolution
 - Fast response
- High brightness and contrast ratio
- Easy and flexible to use
- Brightness, contrast and peaking adjustment with rotary controls
- Color/monochrome picture switchable
- Tally on-low-off switch
- Operator-only tally indicator
- Underscan mode for full picture visibility off shoulder
- 2 (task) assignable buttons
- Diopter compensation range

Specifications

Connectors

Camera connector: 20-pin Hirose

Controls

2 assignable user buttons
Brightness rotary control
Contrast rotary control
Combined menu/Peaking rotary control

Indicators

LED indicators inside:

ISO (yellow)
On-air (red)
Call (green)

LED indicators front:

1x on-air (red) adjustable

General

Power consumption: 3.9W (supplied by camera head)
Operating temperature: -20°C to +45°C (-4°F to 113°F)
Storage temperature: -25°C to +70°C (-13°F to 158°F)
Weight: 900 grams (2.0 lbs.)

LCD

Diagonal size: 51 mm (2.0")
Resolution: 960x540 pixels (QHD)
Response rate: 16 ms

Performance

Color depth: 16.7 million colors
8-bit color
Brightness: 250 cd/m²
Contrast ratio: 200:1
Color temperature: 6500K (adjustable)
Pixel pitch: 0.047 mm x 0.047 mm
Supported formats: All current HD formats
Input signals: Y,Pr,Pb

The viewfinder's LCD panel is manufactured using high-precision technology that yields a pixel response of 99.99% or higher.

VF 8-100-H Viewfinder

The VF 8-100-H viewfinder for the Grass Valley LDX 100 Series cameras has native HD resolution in addition to high brightness and contrast as well as fast refresh rate, making it ideal for both indoor and outdoor use.



The VF 8-100-H is a compact, high-quality, flat panel color viewfinder designed to work with Grass Valley LDX 100 Series system cameras. The stylish design allows for direct mounting to the mini wedge plate of the camera head in both EFP and SuperXpander configurations.

With native HD 1920x1080 pixels, panel focusing becomes easy. In combination with high brightness and contrast, and a fast display refresh rate, the VF 8-100-H is the perfect color viewfinder for both indoor and outdoor applications.

The VF 8-100-H color viewfinder has an intuitive menu structure which not only allows for settings of the viewfinder, but can also be used to activate WFM and

Vectorscope functionality. Three rotary controls, for contrast, brightness and peaking settings, are easily accessible at the front panel.

It is possible to choose between two different mounting brackets that differ in their flexibility and adjustment range. The robust mounting bracket offers a lightweight, compact and very cost-effective solution in which the viewfinder can be rotated horizontally and swiveled up and down, but the height of the center of the screen cannot be changed. The larger and more flexible articulated mounting bracket also allows the height of the viewfinder to be adjusted, resulting in better ergonomics for the user in many applications.

Key Features

- 7-inch LCD panel with LED backlight
- High brightness and contrast
- Full HD resolution with 1920x1080 pixels
- Adjustable box and markers
- Waveform and Vectorscope can be superimposed
- Supports all current and future formats
- Supports 4K/UHD operation
- Standalone operation with SDI or HDMI interface
- Fast response time
- Easy accessible viewfinder menu via viewfinder controls
- Two different mounts to choose from, the cost effective robust mount and the more flexible articulated mount

Specifications

Connectors

Camera connectors:

Future proof 9-pin Fisher connector
SDI input
HDMI input
DC input: XLR 4-pin

Controls

Menu button
Menu rotary
Input button
Marker button
Mono button
Power On/Off
Brightness rotary control
Contrast rotary control
Peaking rotary control

Indicators

LED indicators front:

ISO (yellow)
On-air (red)
Call (green)

LED indicators back:

On-air (red) selectable: off/low/high

General

Power consumption: 16W
Operating temperature: -20°C to +45°C (-4°F to 113°F)
Storage temperature: -25°C to +70°C (-13°F to 158°F)
Weight: 1.2 kg (2.65 lbs.) without accessories

LCD*

Diagonal size: 177.8 mm (7 in.)
Active video: 16:9 1920 (H) x 1080 (V) pixel
Viewing angle: 170° in horizontal and vertical

Performance

Color depth: 16.7 million colors
8-bit color
Brightness: 350 cd/m²
Contrast ratio: 1100:1
Color temperature: 6500K/9300K/user selectable
Pixel pitch: 0.081 x 0.081 mm
Supported formats: All current HD formats

Supplied Accessories

Short sunhood
Cabling
User's guide

* The viewfinder's LCD panel is manufactured using high-precision technology that yields a pixel response of 99.99% or higher.

Note: VF 8-100-H is compatible with the LDX 100 Series cameras only

VF 8-100-H Viewfinder Dimensions

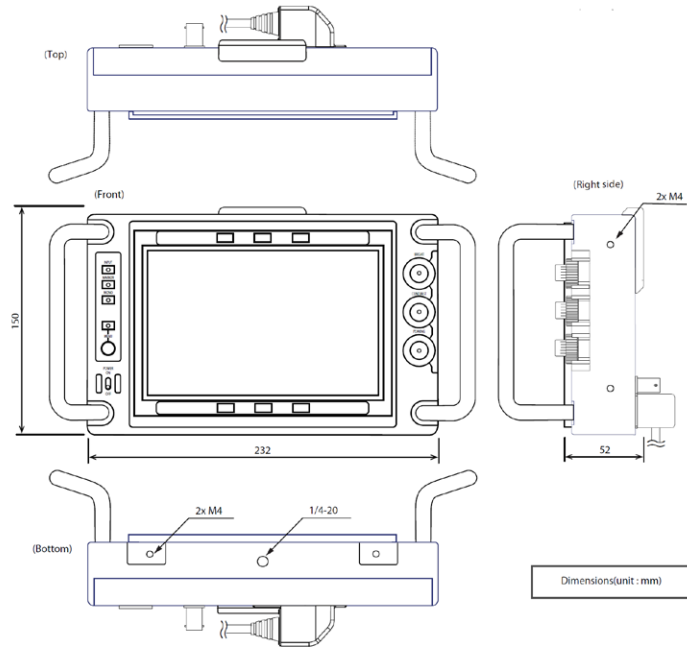

Robust Mounting Bracket

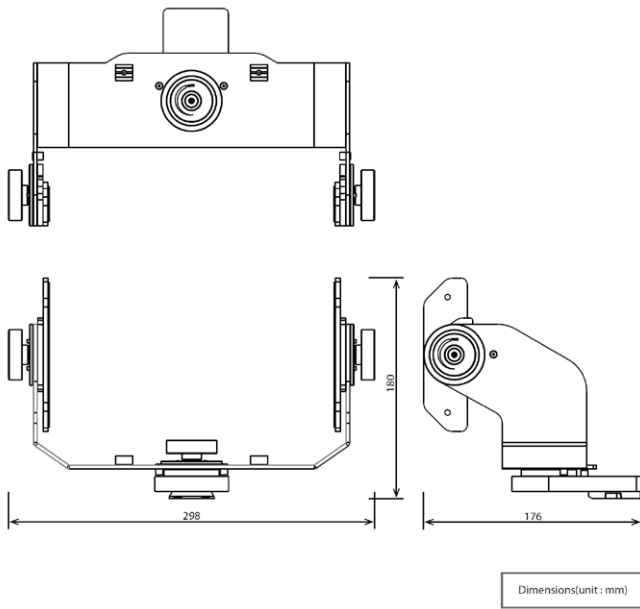

Articulated Mounting Bracket

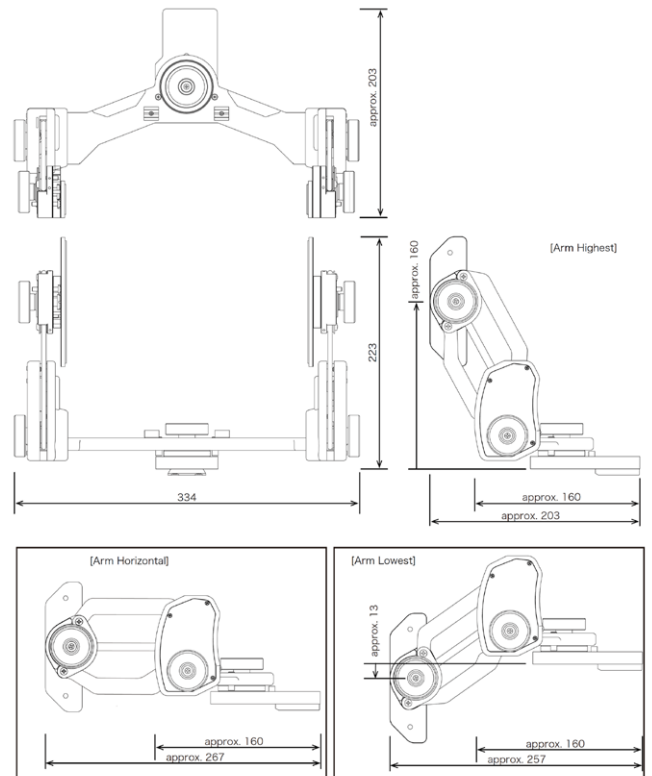

EYECATCHER EC 2-100 Viewfinder



The eyes are the most important tools used during a production. Every detail of a shot is important—and the operator must be able to rely on what they are seeing. The **EyeCatcher EC 2-100** color ocular viewfinder provides users with the confidence to know what they see is what is also being seen in the control room and by viewers.

The Grass Valley EyeCatcher EC 2-100 is a high performance color LCD ocular viewfinder for the LDX camera heads. It is part of a full line of state-of-the-art color viewfinders and is very feature-rich with an intuitive user interface. The EyeCatcher viewfinder also has a stylish look and compact design.

EyeCatcher EC 2-100 offers the best possible image performance, high-speed response time, QHD resolution of 960x540 pixels and a diagonal size of 5.1 cm (2.0 in.). The controls are easy and flexible, similar to the Grass Valley 7-inch and 7.4-inch color LCD viewfinders. It comes with two (task) assignable user buttons and a -3 to +1 diopter compensation range.

Key Features

- Stylish look and compact design
- Offers the best possible image performance:
 - High resolution
 - Fast response
- High brightness and contrast ratio
- Ergonomic design for comfortable shooting
- Easy and flexible to use
- Intuitive viewfinder menu
- Camera menu easily accessible via viewfinder controls
- Brightness, contrast and peaking adjustment with rotary controls
- Color/monochrome picture switchable
- Tally on-low-off switch
- Operator-only tally indicator
- Underscan mode for full picture visibility off shoulder
- 2 (task) assignable buttons
- Adjustable diopter
- Compatible with all LDX 100 Series cameras

Specifications

Connectors

Camera connector: Future proof 9-pin Fisher connector

Controls

2 assignable user buttons
Brightness rotary control
Contrast rotary control
Combined menu/Peaking rotary control

Indicators

LED indicators inside:

ISO (yellow)
On-air (red)
Call (green)

LED indicators front:

1x on-air (red) adjustable

General

Power consumption: 3.9W (supplied by camera head)
Operating temperature: -20°C to +45°C (-4°F to 113°F)
Storage temperature: -25°C to +70°C (-13°F to 158°F)
Weight: 900 grams (2.0 lbs.)

LCD

Diagonal size: 51 mm (2.0")
Resolution: 960x540 pixels (QHD)
Response rate: 16 ms

Performance

Color depth: 16.7 million colors
8-bit color
Brightness: 250 cd/m²
Contrast ratio: 200:1
Color temperature: 6500K (adjustable)
Pixel pitch: 0.047 mm x 0.047 mm
Supported formats: All current HD formats
Input signals: Y,Pr,Pb

The viewfinder's LCD panel is manufactured using high-precision technology that yields a pixel response of 99.99% or higher.

Note: EyeCatcher EC 2-100 is compatible with the LDX 100 Series cameras only

RefleX SuperXpander

The **RefleX SuperXpander** is the perfect match for LDX cameras using the unique 3G Transmission system or XF Fiber Transmission system and turns a comfortable shoulder camera quickly and easily into a full-featured studio camera.

Grass Valley broadcast products offer production professionals the most comprehensive multiformat solutions for acquisition, production, storage and playback, as well as a strong foundation for centralized, proactive status and activity monitoring. The Grass Valley RefleX SuperXpander is such a solution. Compatible with the latest 3G Transmission family and the XF Fiber Transmission system, it supports box-type lenses, teleprompters and high-resolution viewfinders.

For sports and events coverage, the use of large zoom lenses is a common requirement. The RefleX SuperXpander acts as a large lens adapter, rapidly converting a portable camera into a full-featured studio camera.

The lightweight RefleX SuperXpander provides secure mounting and balancing for the largest prompter monitors. For increased simplicity, the camera can remain mounted inside the RefleX SuperXpander housing for transport, saving rigging time and precious space, while ensuring that the camera is aligned and ready to go immediately. Alternatively, the camera can be mounted or released from the housing quickly so it can be switched between pedestal, box lens and handheld applications working with an ENG style lens — even during a live program.

The RefleX SuperXpander can be used with all Grass Valley viewfinders, providing an unprecedented degree of freedom. The unique design of the RefleX SuperXpander system puts even a large viewfinder close to the optical axis of the camera, making camera

movements and positioning more intuitive for the operator to ensure that the shot is right every time.

The new hot shoe connector between the camera and the RefleX SuperXpander provides all power and signal connectivity — making it quick, convenient and reliable, with no need for extra cabling. The hot shoe connector also makes the RefleX SuperXpander transmission system-agnostic — 3G Fiber, 3G Triax and XF Fiber camera systems can be used with the same SuperXpander without the need of switching modules.

For operator convenience, the RefleX SuperXpander is equipped with a functional control panel placed at the rear of the camera. All camera functions can be selected through this panel with its intuitive button layout, with three of the buttons assignable by the operator. These buttons have a sophisticated backlight to improve readability in all lighting conditions and to indicate the status of the buttons.

Two utility power connectors are provided to drive external equipment. Each connector (XLR-4 female) is rated at 13.8V/8 amps. or 120W maximum (combined).



RefleX SuperXpander – Fast and Easy Docking

Key Features

- Supports LDX cameras
- Transmission system-agnostic
- Supports 3G Transmission and XF Fiber Transmission products
- Improved rapid mounting of camera and box lens
- Direct connection of viewfinder to the camera
- Rock-solid configuration for all sizes of large lenses
- Convenient camera control panel at the rear
- Three assignable control buttons
- Mounting and balancing available for all prompter monitors
- Two fixed utility output connectors: 13.8V@8A each or 120W max. (combined)

Specifications

- Dimensions (L x W x H): 526 x 287 x 347 mm (20.7 x 11.3 x 13.7 in.)
- Weight (approx.): 8.5 kg (18.7 lbs.)
- Operating temperatures: -20°C to +45°C (-4°F to +113°F)
- Storage temperatures: -20°C to +60°C (-4°F to +140°F)
- Power supply: supplied by the base station
- Power consumption: 250 VA max. fully equipped (supplied by the base station)
- Utility power outputs: 2x 13.8 VDC XLR-4 female connector, 120 W max. (combined)
- Lens interface: 36-pin Centronics female connector





Ordering

Ordering Options for LDX 90 Series

VF 800-H

7-inch native HD VF for LDX 90 series

EC 200

EyeCatcher 2" LCD viewfinder

Ordering Options for LDX 100 Series

VF 8-100-H

7-inch native HD VF for LDX 100 series

EC 2-100

EyeCatcher 2" LCD viewfinder

Ordering Options for both LDX 90 and LDX 100 Series

LDK 4475/00

RefleX SuperXpander

LDK 6505/30

VF Shelf Slide

LDK 6505/00

Wedge Plate

LDK 5031-10

Tripod Adapter

1-4920700-0100

Long Sunhood

1-4910700-0100

Robust Bracket

1-4910700-0200

Articulated Bracket

This product may be protected by one or more patents. For further information, please visit: www.grassvalley.com/patents

DS-PUB-3-1024D-EN

Grass Valley®, GV®, GV Grass Valley®, and the Grass Valley logo are trademarks or registered trademarks of Grass Valley USA, LLC, or its affiliated companies in the United States and/or other jurisdictions. Grass Valley products listed above are trademarks or registered trademarks of Grass Valley USA, LLC or its affiliated companies, and other parties may also have trademark rights in other terms used herein. Copyright © 2022-2024 Grass Valley Canada. All rights reserved. Specifications subject to change without notice.

www.grassvalley.com Join the Conversation at GrassValleyLive on [Facebook](#), [X](#), [YouTube](#) and Grass Valley on [LinkedIn](#)