

# LDX 100 CAMERA SERIES

## Introducing the Next Generation of Premium Live Image Capture



A new NativeIP™ camera platform that perfectly answers the need for easy reconfiguration in live sports and entertainment productions.

While demand for engaging live content has never been higher, creating and distributing that content has become increasingly complex. Along with local infrastructure and available bandwidth, production formats change from event to event, creative teams are scattered in multiple locations, and time for training operators or maintaining equipment is limited.

The new LDX® 100 series of premium live production cameras from Grass Valley® easily navigates those constraints. Working at the intersection of great technology and ease of use, each model in the series supports NativeIP as well as SDI in your choice of HD, UHD, HDR and High-speed for attention-grabbing images paired with an unmatched set of usability features that greatly simplify the production process.

Camera models in this series include:

- LDX 135
- LDX 150
- LDX C135
- LDX C150
- LDX 135 RF

### Series at a Glance

	LDX 135/LDX C135	LDX 150/LDX C150
Shutter	Global	Global
Imager	3X Xenios capturing 100% Red, 100% Green, 100% Blue	3X Xenios capturing 100% Red, 100% Green, 100% Blue
Sensitivity @2000 lux	F11	F11
Total pixel count	24,883,200	24,883,200
Native UHD operation	Standard	Perpetual or daily option
High speed	N/A	3x HD/UHD, 6x HD with perpetual or daily option
Connectivity	SDI or NativeIP with no external conversion Option activates built-in JPEG XS compression	SDI or NativeIP with no external conversion Option activates built-in JPEG XS compression

## What sets LDX 150/LDX C150 apart?

The LDX 150 is Grass Valley's highest performing live broadcast camera. Its base model is a single-speed HD camera that can connect to an XCU™ of the XCU UXF series (Enterprise, Universe, Xpress), and can slide right into any existing baseband configuration. With additional software licenses, the LDX 150 offers triple-speed UHD or up to 6x speed HD for super slo-mo, streaming directly into your IP infrastructure by using its NativeIP capabilities.

## What sets LDX 135/LDX C135 apart?

Offering a lower entry price point, the LDX 135 stretches production resources farther with features similar to the LDX 150, such as faster turnaround and configuration times, à la carte daily options, and UHD with HDR, without the 3x/6x high-speed that is possible with the LDX 150/LDX C150.

The LDX C150/C135 are the compact versions of the LDX 150/135 respectively, offering the same features and functionality as the full size versions. It is unique in its ability to provide SDI and NativeIP full SMPTE ST 2110 connectivity straight from this compact camera, with no external conversion. In today's live production environment, Grass Valley understands the need to adapt on an event-by-event basis. We're worrying about that so you don't have to.

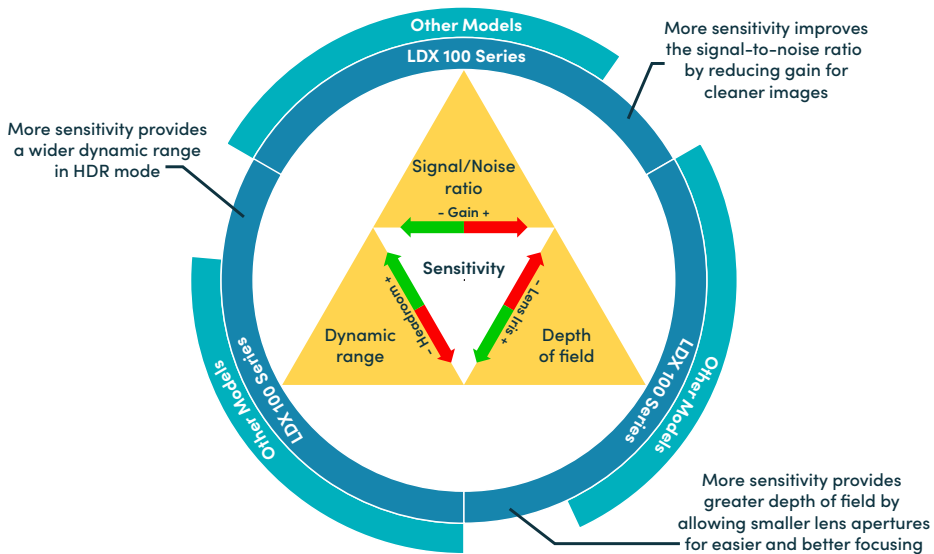

By using the all-new Xenios imagers, the LDX 100 series can capture up to 3x speed UHD natively in Global shutter, where up to triple-speed the output signals are available in native UHD resolution and at 6x speed they are available as down-converted 1080p signals. Based on decades of experience paired with the latest in technology, each of these imagers has been designed from scratch to achieve the next step in broadcast imaging. This means that the camera provides a stunning F11 sensitivity @ S/N ratio of 62 dB in combination with an outstanding level of >15 f-stops of dynamic range in native UHD operation. In addition, the Modulation Transfer Function (MTF), a measurement of the imager's ability to capture resolution and contrast, is through the roof. An improved pixel structure precisely directs the light onto the photodiode and reduces scattering loss. This means that the finest details are captured without losing their brilliance by blending into adjacent pixels.

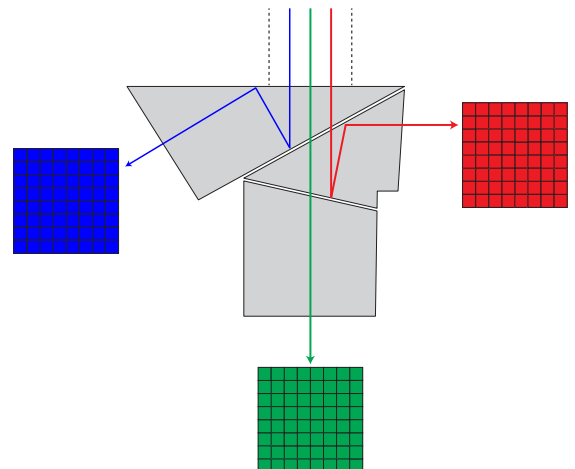

Unlike some competing models, the LDX 100 series has three of these Xenios imagers paired with high precision to a Wide Color Gamut beam splitter. This allows you to capture even the extreme colors that are frequently used in staged events and sports team colors.

For easy color grading, the LDX 100 series can be set to a compatible mode that matches with other LDX models and third-party solutions.

## Key Features

- New camera platform designed for extension into the future
- Simple, scalable multiformat image capture and distribution
- All-in-one camera with no separate base station required thanks to NativeIP
- Supports SMPTE ST 2110 standard as well as AMWA NMOS
- Up to five JPEG XS encoders may be enabled, reducing bandwidth requirements by 20 times
- Backward compatible for SDI connectivity using XCU base stations from the UXF series (Enterprise, Universe, Xpress)
- Fastest time to deploy and configure
- Extensive operator training not required
- At-a-glance settings and diagnostics for immediate status recognition
- Field-tested rugged and reliable
- Suite of inventory management features
- Quickly align camera configuration to production requirements for superior cost management
- Field-replaceable SFP/QSFP
- Save time by managing camera information and licenses from the LDX Scanner app (using NFC technology) without powering up the camera
- LDX 135 RF variant for wireless applications

## Common Features in the Series

Designed to reveal in detail the intensity and emotion behind fast-paced action and split-second decisions, LDX 100 series cameras capture Ultra High Definition (UHD) High Dynamic Range (HDR) images.

Just as compelling as its image capture capabilities is the camera's redefinition of signal distribution. Born a network native, the cameras are self-contained IP endpoints with up to 100 Gb/s IP network connections for audio, video and control directly at the camera head that enable distribution of camera sources wherever they are needed on the network — without the delays inherent in sending signals to a separate control hub.

New topologies are possible for signal acquisition and distribution. The LDX 100 series eliminates the requirement for traditional SDI interconnects, thereby enabling a high level of distribution flexibility including true REMI integration that requires less bandwidth because only the needed signals are transmitted. Efficiency also goes up as multiple creative teams have immediate, nonconflicting access to all camera sources wherever it's best for them to work. Collaborative production has never been easier.

LDX 100 series cameras offer feature sets that everyone on the team will appreciate.

### For the Production Team

Production tools for the new formats of premium content have been limited by the available bandwidth and processing capability. LDX 100 series cameras provide UHD image capture from the same camera directly from the camera head.

Wide color gamut combined with the extensive freedom of Grass Valley's Creative Grading control allows camera shaders to easily create a uniquely branded look and apply it across all the cameras on the network for a signature production that captivates the audience. TDs will also love the on-board GPS that enables a faster response time by intuitively seeing the physical location of a camera, not just its IP address.

Camera operators will love the fast boot time and at-a-glance status indicators that allow them to get right to work. Onboard diagnostics that are available even while the rest of the system is being set up provide immediate feedback to know that you're good to go. Viewfinder menus provide confidence on resolution and frame rate settings.

The function-centric menus provide quick, logical access to camera settings and are grouped so that operators can safely change settings without accidentally affecting other parameters while on-air. LDX 100

series cameras provide a secure user environment that enables operators to work with confidence — even without extensive training.

But just capturing the image isn't enough. Today's environments require multiple unique content variants from a single production. LDX 100 series cameras simplify creation of multiple formats with NativeIP connections directly into the network. Proven standards-based IP makes it simple to connect, convert resolution, map HDR and use however needed across the network. The LDX 100 series makes collaboration a functional model. Whether working locally or remotely, every creative team immediately has access to the sources they need for their parts of the production.

## For Engineers

The number and variety of inputs and outputs for a live production continues to grow. It's the most valuable content available so everyone wants a piece of it. Unfortunately, production budgets haven't expanded at the same pace. Fortunately, Grass Valley has a solution. Offering a significant reduction in configuration and operational complexity, LDX 100 series cameras allow you to quickly set up either on-site or REMI configurations so that you can focus on other issues.

The LDX 100 series offers backwards compatibility with the XCU UXF series up to single-speed UHD. Options on the Cradle for either SDI or IP signals allow you to migrate from baseband to IP at your own pace. And once you're fully IP, you can easily switch to NativeIP mode and get more flexibility with fewer components. No XCU or cradle is required, eliminating the 2 RU of rack space and weight per camera that is required for other systems.

LDX 100 series are native IP cameras that don't rely on extra equipment to manage the communications. Instead, the camera itself is the active IP endpoint in the network. We call this NativeIP. NativeIP allows you to add a camera to your production system from wherever a network connection is available. With less hardware to set up, time to set up and configure is reduced while the number of potential camera locations is increased.

When production formats change or there are restricted local infrastructure requirements, an exchange in the field to a different

bandwidth SFP connector takes just seconds. The series supports field-swappable SFP and QSFP connectors at various bitrates. When bidirectional SFPs are being used, each of the two fibers in the robust SMPTE hybrid cable carries a unique bidirectional IP link that enables redundancy straight from the camera body.

When new workflows with even lower bandwidth are needed, LDX 100 series cameras uniquely support JPEG XS compression on board. No external gear is required to provide broadcast-quality compression right at the source. Achieve very efficient network utilization at 5 to 20 times less typical video bandwidth rates with the minimum possible delay — only 12 lines of encoding time!

Even faster is the dynamic connectivity available with multiplexed IP connections. You can switch to new camera configurations with a single click. Implementation of AMWA-NMOS protocols means

the camera is instantly discovered and connected to a network control system such as Grass Valley's GV Orbit®. The implementation of common IP standards provides simple integration of audio, video and control as well as superior PTP timing. Support includes management of camera tally information, audio levels, control panel button presses and status using industry standard integration.

All of this functionality is an integral part of the media stream so the system is much easier to scale. Cameras can be added anywhere in the network. Authorized users can simultaneously access the same video and audio streams from any workstation. Even when audio is mixed in a completely different part of the world. In addition, since return signals from a production hub are no longer required, signal delays and total network bandwidth requirements are reduced.



## For Equipment Owners

In a rapidly evolving production environment, the last thing you want to worry about is whether the camera can keep pace. LDX 100 series has all of the high-performance characteristics required of a professional working camera today while offering extensive upgrade capability for the requirements of tomorrow. You can start deploying it as an HD camera doing 1080p productions and then use à la carte software licensing to continue to add features up to triple-speed UHD as your production needs change.

Consider its rugged durability. The LDX 100 series' ergonomic design not only makes the camera easier to handle, its field-tested exterior sports a bumper for low shots, and its all new cooling design makes the camera "Champagne shower" proof! It's no less reliable internally. Inheriting the high reliability of the proven LDX 80/90 series, LDX 100 features superior cooling and fewer connections to maintain a long operational life.

Using LDX 100 series cameras on a production also enables you to more closely match production costs to a specific job. LDX 100 series allows

you to pay for features only when required. Apply generic credits from your Grass Valley Order Desk to enable options as needed on a daily or multiple day basis.

Growing into tomorrow's requirements is worry-free with the LDX 100 series. If you are primarily producing in HD SDI today, LDX 100 offers you complete compatibility with Grass Valley's existing XCU. But that same camera can be taken from an SDI environment and plugged into an IP network without any transition concerns. Work in any combination or hybrid environment — and do it whenever you need to do it.

## Operational Efficiency with NFC and LDX Scanner

The LDX 100 series reduces time spent looking after cameras. Once you send an LDX 135 or LDX 150 camera out on the road, it may never have to return to the warehouse again. A suite of revolutionary inventory management features for streamlined logistical operations includes wireless Near Field Communication (NFC) that reduces handling time by several minutes every time you ship a camera. With NFC you can use a mobile phone to read usage information on check-out/check-in and load options into your equipment so that it is fully ready to operate for the next production — without ever powering up the camera! Just download and open the app, hold your phone close to the NFC mark on the camera, and then select the tabs for camera info and licenses. It's that simple.

The app for the LDX Scanner is now available on both the Apple and Android stores.

The new camera platform is planned for extensive upgrade capability while allowing a hybrid operation that evolves at your own pace. In addition to enabling just the features you need, the Grass Valley camera portfolio allows you to mix and match LDX camera models in the same system as well as components among models such as control panels, 2/3-inch lenses, and power supplies. LDX 100 series also supports field-swappable SFP connectors at speeds of 10 Gb/s, 25 Gb/s, bidirectional 25 Gb/s and 100 Gb/s QSFP to meet growing bandwidth requirements. In the uncertain world of evolving production requirements LDX 100 series is a safe investment today that will ensure best performance for years to come.

Continuing in that philosophy of creating forward-looking value, Grass Valley's new Creative Grading control panel and tablet application not only make cameras simpler and faster to access, they eliminate the requirement to match one OCP per camera. Creative Grading panels can work across multiple cameras, even in multiple formats to create a single, unified look

Creativity, Performance, Cost-effectiveness. Regardless of what aspects of the production chain concern you most, the LDX 100 series has a barrier-breaking solution for your needs.

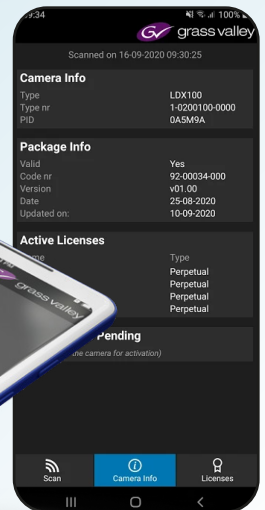

## SPECIFICATIONS — LDX 100 SERIES CAMERA HEADS

### General

#### LDX 150/135

- **Temperature range:** -20° to +45°C (-4° to 113°F) (Recommended temperature range when operating in 6x high-speed operation: -20° to +40°C (-4° to 104°F))
- **Weight:** approx. 5.5 kg (12.1 lbs.)
- **Dimensions (LxWxH):** 380 x 167 x 253 mm (15.66 x 6.56 x 9.93 in.)
- **Power consumption (typ.):** 100W

#### LDX C150/C135

- **Temperature range:** -20° to +45°C (-4° to 113°F) (operating) (Recommended temperature range when operating in 6x high-speed operation: -20° to +40°C (-4° to 104°F))
- **Weight:** 2.9 kg
- **Dimensions (LxWxH):** 225 x 120 x 140 mm (8.86 x 4.72 x 5.51 in.)
- **Power consumption (typ.):** 15 VDC < 100W

#### LDX 135 RF

- **Temperature range:** Operational: -20°C to +45°C (-4° to 113°F)
- **Weight:** approx. 4.9 kg (11 lbs.)
- **Dimensions (LxWxH):** 380 x 167 x 253 mm (15.66 x 6.56 x 9.93 in.)
- **Power consumption (typ.):** 90W (camera)

### Camera

**Pick-up device:** 3x 2.3" UHD Xenios CMOS imagers with global shutter

**Smear:** no vertical smear

**Shutter:** no mechanical shutter

**Optical system:** F1.4 prism

**Lens mount:** 2/3" (B4 type) Bayonet lens mount

**Optical filter wheels:** 2x motorized wheels

**Optical filters on first wheel:** clear, 1/4 ND, 1/16 ND, 1/64 ND, Cap

**Optical filters on second wheel:** clear, 4P-star, soft focus

**Electronic color correction:** 3200°K, 5600°K, 7500°K, FL, 2 AWB presets, variable, continuous auto white

**Sensitivity @2000 lux (typical) + S/N ratio:** F11 @ 62 dB S/N ratio (in 2160p50)

**Aspect ratio:** 16:9

**Modulation depth:** 60% (typical) at 800 TV lines (27 MHz) in 1080i50/59.94 modes

**Digital resolution:** 16-bit A/D-conversion with 34-bit processing in RGB

**Horizontal resolution:** >1,000 TV lines (HD), >2,000 TV lines (4K UHD)

**Gain selection:** -6 dB to +18 dB in 3 dB steps (user-definable presets) or continuous master gain

**Standards compliant:**

SMPTE ST 2110

AMWA NMOS IS-04, -05, -07 and -09

### Connectivity

**Microphone input (front):** XLR-3 female, balanced, with switchable +48V phantom power (not applicable for the LDX C135/C150)

**REF/AES BNC connector:** Reference input, output or AES digital audio

**BNC A to E connectors:** Video BNC baseband connectors, input and output (1.5G, 3G or 12G)

**Camera control network (C2IP):** RJ-45 Ethernet connector (1 Gb/s)

**Ethernet/IP Trunk:** RJ-45 Ethernet connector (1 Gb/s)

**Lens connector:** 12p Hirose connector

**Viewfinder connector:** 9p Fischer MiniMax connector (not applicable for the LDX C135/C150)

**Monitoring video:** Micro HDMI (type D) connector

### Hybrid Fiber connector:

- **LDX 150/135:** SMPTE ST 304 hybrid fiber connector (swiveling)
- **LDX C150/C135:** Neutric opticalCON Duo hybrid fiber connector

### Mounting holes:

- **LDX 150/135:** 2x 1/4" - 20 UNC + 3x M4 threaded holes (camera thread)
- **LDX C150/C135:**  
On top: 2x 3/8" - 16 UNC, 6x 1/4" - 20 UNC, 10x M4  
At bottom: 2x 3/8" - 16 UNC, 4x 1/4" - 20 UNC

**Audio inputs (rear):** 2x XLR-3 female, balanced, with switchable +48 V phantom power (not applicable for the LDX C135/C150)

**Intercom:** XLR-5 with Engineering, Production and Program channels (not applicable for the LDX C135/C150)

### DC Power input:

- 12V (12 to 17V), XLR-4 male <16A
- **LDX C150/C135:** OpticalCON DUO SMPTE power: 20V to 28 VDC <6A

**DC Power output:** 13V, XLR-4 female < 4A DC (not applicable for the LDX C135/C150)

### LDX 135 RF — Connectivity to wireless equipment:

- 12V (12 to 17V), 6P Molex MiniFit battery input <16A
- Switched power output for wireless unit <4A
- 7x MCX SDI: Output interface (1.5G, 3G, 12G)
- 1x MCX SDI: Input (1.5G, 3G) for return video
- 40p Flex: 2x 1 Gb/s Eth control, 3x output IO, 5x input IO, 12C, UART

### Accessories

- 2" LCD viewfinder
- 7" LCD viewfinder

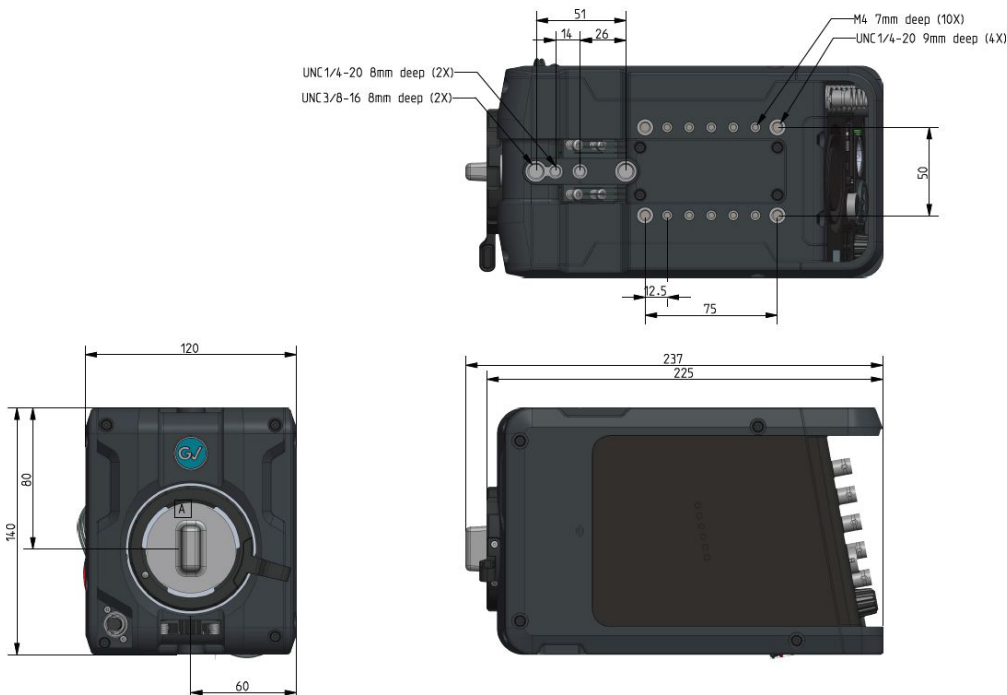

LDX 135 RF Rear View

## SPECIFICATIONS – XF TRANSMISSION

### XCU Xpress UXF

#### Video (specific format support depends on the camera model)

720p: 50/59.94/150/179.82/300/359.64 Hz

1080i: 50/59.94/150/179.82/300/359.64 Hz

1080p: 50/59.94/150/179.82 Hz

4K UHD: 3840x2160p50/59.94

#### Compatible Cameras

LDX 80 Series, LDX 90 Series and LDX 100 Series

#### General (incl. cradle)

Dimensions XCU + cradle (HxWxL, approx.): 448 x 86.5 x 533 mm (19" rack, 2 RU) (17.6 x 3.4 x 21.0 in.)

Operating temperature: 0 to +45°C (+32 to +113°F)

Storage temperature: -20 to +70°C (-4 to +158°F)

Operation humidity: Max. 90% (noncondensing)

Shock resistance: Max. 10G (transport), max. 2G (operating)

Altitude: Max. 15,420m (50,000 ft.)

#### Weight:

XCU + cradle: 12.5 kg (27.6 lbs.)

XCU: 7.8 kg (17.2 lbs.)

Power requirement: AC 100V/240V, 47 to 63 Hz

Power connector: IEC type, 3-pin male

Power consumption: Total power (Camera + XCU) 450W max.

#### Connectors (4K mode)

Teleprompter in: BNC 1x (loop-through output), (C) VBS, 1.0 Vp-p, 75Ω

Reference in: 1x (loop-through output), 1.0 Vp-p, 75Ω HD tri-level sync or SD blackburst

4K UHD: 2x / 3G HD-SDI: 4x, BNC 0.8 Vp-p, 75Ω Quad or 2SI, Level-A

HD-SDI out: BNC 1x 0.8 Vp-p, 75Ω, SMPTE ST 292, 1080i/720p at 50/59.94 Hz or SMPTE ST 425A, 425B, 1080p at 50/59.94 Hz

Signaling in/out: D-sub 15-pin – male, preview, green tally (call – dry contact), yellow tally (iso – dry contact), red tally (on air – dry contact), remote audio level control (22-64 dB), DC

Auxiliary in/out: D-sub 9-pin – female, private data in/out – 100 kb TTL (RS-232)

Control data: RJ-45 connector for C2IP (camera control)

Control data: RJ-45 connector for IP trunk up to 1 GbE

Hybrid fiber connector: LEMO hybrid acc. SMPTE ST 304

External video in: 3x HD-SDI (1.5 Gb/3.0 Gb) or SD-SDI 0.8 Vp-p, 75Ω

Input 1 (loop-through output)

Inputs 2 and 3 (no loop-through output)

#### Connectors (HD/3G 1X/3X/6X modes)

Teleprompter in: BNC 1x (loop-through output), (C) VBS, 1.0 Vp-p, 75Ω

Reference in: 1x (loop-through output), 1.0 Vp-p, 75Ω HD tri-level sync or SD blackburst

HD-SDI out\*: BNC 6x 0.8 Vp-p, 75Ω, SMPTE ST 292, 1080i/720p at 50/59.94 Hz

HD-SDI out (live/effect)\*: BNC 2x 0.8 Vp-p, 75Ω, SMPTE ST 292, 1080i/720p at 50/59.94 Hz

HD-SDI monitoring out: BNC 1x 0.8 Vp-p, 75Ω, SMPTE ST 292, 1080i/720p at 50/59.94 Hz

SD-SDI out: BNC 2x 0.8 Vp-p, 75Ω, SMPTE ST 259 ITU-R, BT.601

SD-SDI monitoring out: BNC 1x 0.8 Vp-p, 75Ω, SMPTE ST 259 ITU-R, BT.601

Composite video monitoring output: BNC 1x 1.0 Vp-p, 75Ω (CVBS text with video, for viewing purposes)

Signaling in/out: D-sub 15-pin – male, preview, green tally (call – dry contact), yellow tally (iso – dry contact), red tally (on air – dry contact), remote audio level control (22-64 dB), DC

Auxiliary in/out: D-sub 9-pin – female, private data in/out – 100 kb TTL (RS-232)

Control data: RJ-45 connector for C2IP (camera control)

Control data: RJ-45 connector for IP trunk up to 1 GbE

Hybrid fiber connector: LEMO hybrid acc. SMPTE ST 304

External video in: 3x HD-SDI (1.5 Gb/3.0 Gb) or SD-SDI 0.8 Vp-p, 75Ω

Input 1 (loop-through output)

Inputs 2 and 3 (no loop-through output)

\* Notes:

– 8x 1.5G video outputs (in 1X speed 720p, 1080i)

– 6x 3G and 2x 1.5G video outputs (in 1X speed 1080p)

– 2x three phases on 6x 1.5G and 2x 1.5G live (in 3X speed 720p, 1080i)

– 2x three phases on 6x 3G and 2x 6G live (in 3X speed 1080p)

– 2x six phases on 6x 3G (dual-link) and 2x 1.5G live (in 6X speed 720p, 1080i, 1080p)

– During single-speed HDR operation, some of the signals will be with SDR mapping and some of the signals will be with HDR mapping

		XCU Xpress UXF	XCU Xpress UXF + IP option
Full Baseband connectivity		Y	Y
Full IP connectivity		N	Y
12G SDI support		Y	Y
HD/3G/4K UHD support in single speed		Y	Y
High speed support	3X HD, 6X HD, 3X 3G	Y	Y
	6X 3G	Y	Y*
DirectIP(+) support		Y	Y
HDR support	in single speed	Y	Y
	in high speed	Y	Y
Simultaneous outputs in: 4K HDR, 3G/HD HDR, 3G/HD SDR		Y	Y
LDX 100 series support		Y	Y
Delivered with UXF cradle with 4x SFP+ slots		Y	Y

\* 6x 3G not supported over IP

## TECHNICAL SPECIFICATIONS — XF TRANSMISSION (cont.)

### Signaling and Control

Signaling in/out: D-sub 15-pin, male; preview, green tally (call), dry contact; yellow tally (iso), dry contact; red tally (on air), dry contact; remote audio level control (22-64 dB), DC

Auxiliary in/out: D-sub 9-pin, female; private data in/out; 100 kb TTL (RS-232)

Control data: RJ-45 connector for C2IP (camera control)

### Audio

2-ch. audio: Audio out, XLR-3 2x ; 0/+6 dBu ( $\pm 1.5$  dB, max. 18 dBu, 600 $\Omega$ , gain max. 70 dB)

Frequency response: 40 Hz to 15 Hz, (+1/-3 dB, 1 kHz, -10 dBu output level)

Distortion: Less than 0.5% (100 Hz/1 kHz, +6 dBu out, 600 $\Omega$ ) S/N ratio: 58 dB (unweighted RMS)

AES-EBU 1+2: BNC 75 $\Omega$ , Dig audio output Audio 1 and 2

AES-EBU 3+4: BNC 75 $\Omega$ , Dig audio output Audio 3 and 4

Intercom in/out (2/4-wire intercom): D-sub 15-pin, female (program in, production in/out, engineering in/out), in: 0 or 6 dBu; out: 0 or 6 dBu ( $\pm 2$  dB, max. 12 dBu)

Frequency response: 150 Hz to 6 kHz (1 kHz, -10 dBu output level)

Distortion: Less than 2% (1 kHz, +12 dBu level)

### Dimensions for all XCU UXF models

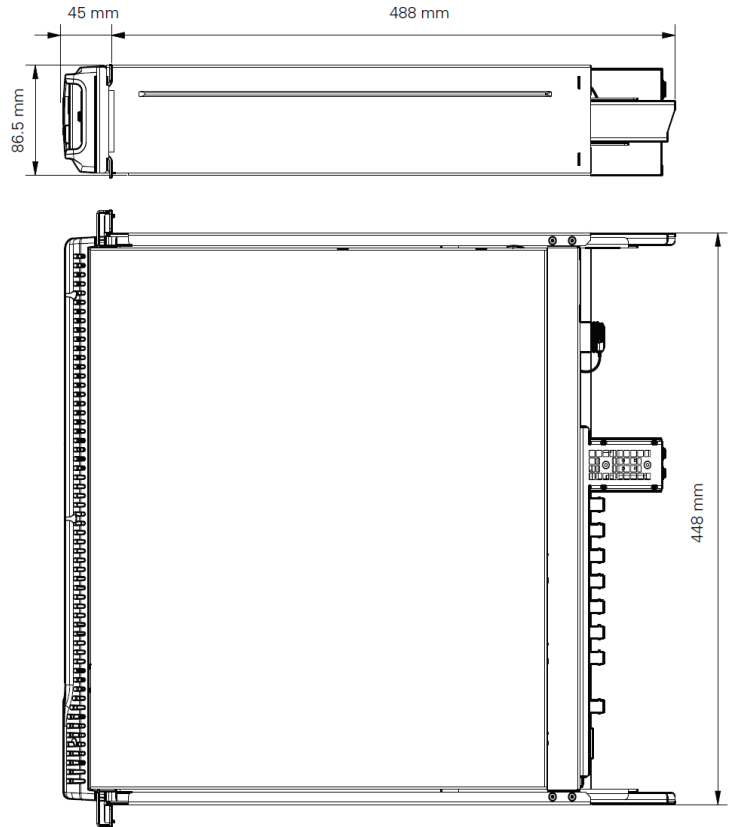

### SMPTE hybrid fiber connection for cameras

### 4x SFP+ connections (optional 12G SDI SFPs can be used in addition to the IP SFPs)

### All the traditional baseband connectivity from regular XCUs while transitioning to IP

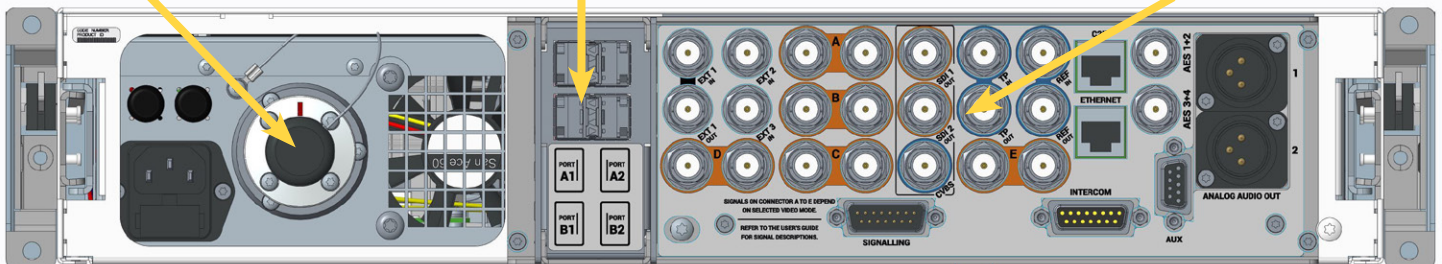



			LDX 100 series	XCU UXF series
IP connectivity	QSFP	100G	1x	–
	SFP+	25G (inc. bidirectional)	2x (Redundancy)	–
	SFP+	10G (inc. bidirectional)	2x (Redundancy)	4x (Redundancy)
Camera Control	C2IP	In-band (vlan) / out-band	yes (via fiber) / yes (via RJ45)	no / yes (via RJ45)
	XML	XML-camera control	yes (via CCS-one)	yes (via CCS-one)
SMPTE ST 2110 -10	PTP	1-step / 2-step (inc. redundancy)	yes / yes	yes / yes
		SMPTE ST 2059-2 / Media profile / AES R16 / user	yes / yes / yes / yes	yes / yes / yes / yes
SMPTE ST 2110 -20/21	Video	Multicast, type N	yes	yes
SMPTE ST 2110 -22	Video	JPEG-XS, Multicast, type N	yes	no
SMPTE ST 2110 -30	Audio	Level A / B / C	yes / yes / no*	yes / yes / no*
SMPTE ST 2110 -30	Intercom	Level A / B / C	yes / yes / no*	yes / yes / no*
SMPTE ST 2022-6	Video		yes	yes
H.264	Video	Proxy	yes	no
NMOS	IS-04	Static / mDNS / DNS-SD (over C2IP)	yes / yes / yes	yes / yes / yes
NMOS	IS-04	Static / mDNS / DNS-SD (over Media: redundant)	yes / yes / yes	yes / yes / yes (port A1 and B1)
NMOS	IS-04	Version	V1.0 / V1.1 / V1.2 / V1.3	V1.0 / V1.1 / V1.2 / V1.3
	IS-05	Over C2IP/Media(redundant)	yes / yes	yes / yes
	IS-05	Version	V1.0 / V1.1	V1.0 / V1.1
	IS-07	MQTT / Websockets	MQTT / no Websockets	MQTT / no Websockets
	IS-07	MQTT over C2IP / MQTT over media (Not Redundant)	yes / yes	yes / no
	IS-09	mDNS / DNS-SD (C2IP + Media)	yes / yes	yes / yes
LLDP			yes	yes
IGMP V2 / V3			yes / yes	yes / yes
DHCP		Over C2IP/Media	yes / yes	yes / yes
DNS		Only in combination with DHCP	yes	yes
SDP		Import*** / Export	yes / yes	yes / yes
IP-Trunk	Access	Up to 1 Gb	yes**	yes
IP-Trunk	VLAN	Multiple VLANs	yes**	yes
Redundancy	2022-7	Video / Audio / Intercom / PTP	yes / yes / yes / yes	yes / yes / yes / yes**
Redundant Control		Control (C2IP) / NMOS	yes / yes	no / yes

\* 1, 2, 4, 8, 16 channels selectable; only 48 kHz support; packet times 1 ms, 250 μs, 125 μs

\*\* Fail-over is implemented for return video, return audio, return intercom and IP-trunk

\*\*\* Import only via IS-05



## Ordering

### Camera Head and Accessories

#### LDX 135

LDX 135 camera head

#### LDX 150

LDX 150 camera head

#### LDX C135

LDX C135 compact camera head

#### LDX C150

LDX C150 compact camera head

#### LDX 135 RF

LDX 135 RF camera head

#### EC 2-100

2-inch Ocular Viewfinder for LDX 100 series

#### VF 8-100-H

7-inch native HD VF for LDX 100 series

#### 10GSFP-EOPT

10G Eoptolink SFP for LDX 100 series used with XCU

### XF Transmission 10 GbE XCU

#### XCU Xpress UXF

SMPTE Fiber Lemo – Includes XCU Cradle (4x SFP+ cages)

### Options

3-speed UHD option for LDX 150/C150

3-speed HD option for LDX 150/C150

6-speed HD option for LDX 150/C150

NativeIP option for LDX 100 series

UHD 50/59.94 option for LDX 100 series

JPEG XS option for LDX 100 series

DirectIP/IP+ option for LDX 100 series

HD Filmic modes for LDX 100 series

UHD Filmic modes for LDX 100 series

Perpetual GPS Option for LDX 100 Series

Perpetual Audio/Intercom channel assignment for LDX 100 Series

### Power Supply Options

#### HPE-300-2AC

Hybrid power extender, 300W, dual AC input with auto-failover. UFP required

#### 15 VDC power supply LDX 100 Series

### Camera Control

#### CGP 500

Creative Grading Control Panel

#### CCS One

Camera Control Server

#### CGA

Creative Grading App



## A la carte Temporary Software Options

The LDX 100 series allows you to upgrade feature by feature, perpetually or just for one day using an à la carte model. Daily (or multiple days) options can be created in the customer's secured B.O.W.L. web portal. A section dedicated to the LDX 100 series has been added to the portal.

### Opt-UHD-4-LDX 100\*

Perpetual UHD 50/59.94 option for LDX 100 series

### Opt-HS-4-LDX 100

Perpetual 3-Speed UHD option for LDX 150 – requires UHD 50/59.94 option and NativeIP option installed

### Opt-HD 6speed-4-LDX 100

Perpetual 6x HD option for LDX 150/C150

### Opt-HD 3+6speed-4-LDX 100

Perpetual 3+6 speed HD option for LDX 150/C150

### Opt-NatIP-4-LDX 100

Perpetual NativeIP option for LDX 100 series

### Opt-DirectIP-4-LDX 100

Perpetual DirectIP/DirectIP+ option for LDX 100 series

### 50CredPoint-4-LDX 100

Bundle of 50 LDX 100 series Option Credit Points

### 500CredPoint-4-LDX 100

Bundle of 500 LDX 100 series Option Credit Points

### 1000CredPoint-4-LDX 100

Bundle of 1000 LDX 100 series Option Credit Points

### GPS Option Perpetual

This unique feature indicates the exact location of the camera as soon as it is connected to the network and Creative Grading system – both graphically on a map and with the coordinates displayed in the Creative Grading App. Ideal for large scale and remote operations. This option is only available as a perpetual option.

### UHD Filmic Modes Perpetual

Enables UHD “filmic” acquisition, in broadcast frame rates (25/29.97) and cinema frame rates (23.98/24/60). (For the UHD Filmic option the UHD 50/59.4 Option, 9-0110000105-9, is required.) The UHD Filmic option is also available as a daily option in the B.O.W.L. portal.

### LDX 100 Series Audio/Intercom Channel Assignment Option

Enables selection of intercom/audio input and output channel assignment to create complete flexibility for intercom and audio routing inside the camera.

Without this licensed option, customers have the standard available fixed channel assignment for audio and intercom.

### JPEG XS Video Compression Perpetual

This high-quality low-latency video compression option creates the compressed video signal in the camera when running in NativeIP, saving external equipment. Extremely beneficial for remote productions to save significant bandwidth. Single-speed HD and UHD signals can be compressed. The JPEG XS compression option is only available as perpetual option.

Any available option can easily be created in the LDX 100 section of the B.O.W.L. web portal against Option Credit Points.

\* Not required for LDX 135/C135, which supports UHD 50/59.94 operation as standard

		Model		Options		
Requirement	Details	LDX 135/ C135	LDX 150/ C150	Item Number	Commercial Reference	Points
1080i	50, 59.94	✓	✓			
1080PsF	23.98, 24, 24, 29.97	○	○	9-0110000103-9	HD Filmic – Broadcast (25/29.97) Cinema (23.98/24/60)	1
1080p	50, 59.94	✓	✓			
3x Speed	1080i, 1080p	✗	○	9-0110000101-9	LDX 100 Series 3-speed HD Option	4
6x Speed	1080i, 1080p	✗	○	9-0110000136-9	Opt-HD 6speed-4-LDX 100 series	5
3x/6x Speed	1080i, 1080p	✗	○	9-0110000137-9	Opt-HD 3+6speed-4-LDX 100 series	6
4K UHD	23.98, 24, 25, 29.97	○	○	9-0110000108-9	Perpetual UHD Filmic Option for LDX 100 Series – Requires UHD 50/59.94 option	2
4K UHD	50, 59.94	✓	○	9-0110000105-9	Perpetual UHD 50/59.94 option for LDX 100 Series	4
3x Speed	4K UHD	✗	○	9-0110000106-9	Perpetual 3-speed UHD option for LDX 150 – Requires UHD 50/59.94 option and NativeIP option installed	6
NativeIP		○	○	9-0110000110-9	Perpetual NativeIP option for LDX 100 Series	4
JPEG XS	For NativeIP	○	○	9-0110000114-9	Perpetual JPEG XS video compression option for LDX 100 Series	N/A
GPS	For NativeIP	○	○	9-0110000112-9	Perpetual GPS option for LDX 100 Series	N/A
DirectIP(+)	For XF transmission	○	○	9-0110000111-9	Perpetual DirectIP/DirectIP+ option for LDX 100 Series	3
Audio/I-comm	For NativeIP	○	○	9-0110000128-9	Opt-Audio/Intercom Chan. Assign. LDX 100 series	N/A
HDR	PQ, HLG, S-Log3	✓	✓			
WCG	BT.2020	✓	✓			
		✓ Standard	○ Optional	✗ Not supported		

# EYECATCHER EC 2-100 Viewfinder



The eyes are the most important tools used during a production. Every detail of a shot is important—and the operator must be able to rely on what they are seeing. The **EyeCatcher EC 2-100** color ocular viewfinder provides users with the confidence to know what they see is what is also being seen in the control room and by viewers.

The Grass Valley EyeCatcher EC 2-100 is a high performance color LCD ocular viewfinder for the LDX camera heads. It is part of a full line of state-of-the-art color viewfinders and is very feature-rich with an intuitive user interface. The EyeCatcher viewfinder also has a stylish look and compact design.

EyeCatcher EC 2-100 offers the best possible image performance, high-speed response time, QHD resolution of 960x540 pixels and a diagonal size of 5.1 cm (2.0 in.). The controls are easy and flexible, similar to the Grass Valley 7-inch and 7.4-inch color LCD viewfinders. It comes with two (task) assignable user buttons and a -3 to +1 diopter compensation range.

## Key Features

- Stylish look and compact design
- Offers the best possible image performance:
  - High resolution
  - Fast response
- High brightness and contrast ratio
- Ergonomic design for comfortable shooting
- Easy and flexible to use
- Intuitive viewfinder menu
- Camera menu easily accessible via viewfinder controls
- Brightness, contrast and peaking adjustment with rotary controls
- Color/monochrome picture switchable
- Tally on-low-off switch
- Operator-only tally indicator
- Underscan mode for full picture visibility off shoulder
- 2 (task) assignable buttons
- Adjustable diopter

## Specifications

### Connectors

**Camera connector:** Future proof 9-pin Fisher connector

### Controls

2 assignable user buttons  
Brightness rotary control  
Contrast rotary control  
Combined menu/Peaking rotary control

### Indicators

#### LED indicators inside:

ISO (yellow)  
On-air (red)  
Call (green)

#### LED indicators front:

1x on-air (red) adjustable

### General

**Power consumption:** 3.9W (supplied by camera head)  
**Operating temperature:** -20°C to +45°C (-4°F to 113°F)  
**Storage temperature:** -25°C to +70°C (-13°F to 158°F)  
**Weight:** 900 grams (2.0 lbs.)

### LCD

**Diagonal size:** 51 mm (2.0")  
**Resolution:** 960x540 pixels (QHD)  
**Response rate:** 16 ms

### Performance

**Color depth:** 16.7 million colors  
**8-bit color**  
**Brightness:** 250 cd/m<sup>2</sup>  
**Contrast ratio:** 200:1  
**Color temperature:** 6500K (adjustable)  
**Pixel pitch:** 0.047 mm x 0.047 mm  
**Supported formats:** All current HD formats  
**Input signals:** Y,Pr,Pb

The viewfinder's LCD panel is manufactured using high-precision technology that yields a pixel response of 99.99% or higher.

Note: EyeCatcher EC 2-100 is compatible with the LDX 100 series cameras only

# VF 8-100-H Viewfinder

The VF 8-100-H viewfinder for the Grass Valley LDX cameras has native HD resolution in addition to high brightness and contrast as well as fast refresh rate, making it ideal for both indoor and outdoor use.



The VF 8-100-H is a compact, high-quality, flat panel color viewfinder designed to work with Grass Valley LDX system cameras. The stylish design allows for direct mounting to the mini wedge plate of the camera head in both EFP and SuperXpander configurations.

With native HD 1920x1080 pixels, panel focusing becomes easy. In combination with high brightness and contrast, and a fast display refresh rate, the VF 8-100-H is the perfect color viewfinder for both indoor and outdoor applications.

The VF 8-100-H color viewfinder has an intuitive menu structure which not only allows for settings of the viewfinder, but can also be used to activate WFM and

Vectorscope functionality. Three rotary controls, for contrast, brightness and peaking settings, are easily accessible at the front panel.

It is possible to choose between two different mounting brackets that differ in their flexibility and adjustment range. The robust mounting bracket offers a lightweight, compact and very cost-effective solution in which the viewfinder can be rotated horizontally and swiveled up and down, but the height of the center of the screen cannot be changed. The larger and more flexible articulated mounting bracket also allows the height of the viewfinder to be adjusted, resulting in better ergonomics for the user in many applications.

## Key Features

- 7-inch LCD panel with LED backlight
- High brightness and contrast
- Full HD resolution with 1920x1080 pixels
- Adjustable box and markers
- Waveform and Vectorscope can be superimposed
- Supports all current and future formats
- Supports 4K/UHD operation
- Standalone operation with SDI or HDMI interface
- Fast response time
- Easy accessible viewfinder menu via viewfinder controls
- Two different mounts to choose from, the cost effective robust mount and the more flexible articulated mount

## Ordering

### Connectors

#### Camera connectors:

Future proof 9-pin Fisher connector  
SDI input  
HDMI input  
DC input: XLR 4-pin

### Controls

Menu button  
Menu rotary  
Input button  
Marker button  
Mono button  
Power On/Off  
Brightness rotary control  
Contrast rotary control  
Peaking rotary control

### Indicators

#### LED indicators front:

ISO (yellow)  
On-air (red)  
Call (green)

#### LED indicators back:

On-air (red) selectable: off/low/high

### General

**Power consumption:** 16W  
**Operating temperature:** -20°C to +45°C (-4°F to 113°F)  
**Storage temperature:** -25°C to +70°C (-13°F to 158°F)  
**Weight:** 1.2 kg (2.65 lbs.) without accessories

### LCD\*

**Diagonal size:** 177.8 mm (7 in.)  
**Active video:** 16:9 1920 (H) x 1080 (V) pixel  
**Viewing angle:** 170° in horizontal and vertical

### Performance

Color depth: 16.7 million colors  
8-bit color  
Brightness: 350 cd/m<sup>2</sup>  
Contrast ratio: 1100:1  
Color temperature: 6500K/9300K/user selectable  
Pixel pitch: 0.081 x 0.081 mm  
Supported formats: All current HD formats

### Supplied Accessories

Short sunhood  
Cabling  
User's guide

\* The viewfinder's LCD panel is manufactured using high-precision technology that yields a pixel response of 99.99% or higher.

Note: VF 8-100-H is compatible with the LDX 100 series cameras only

# VF 8-100-H Viewfinder Dimensions

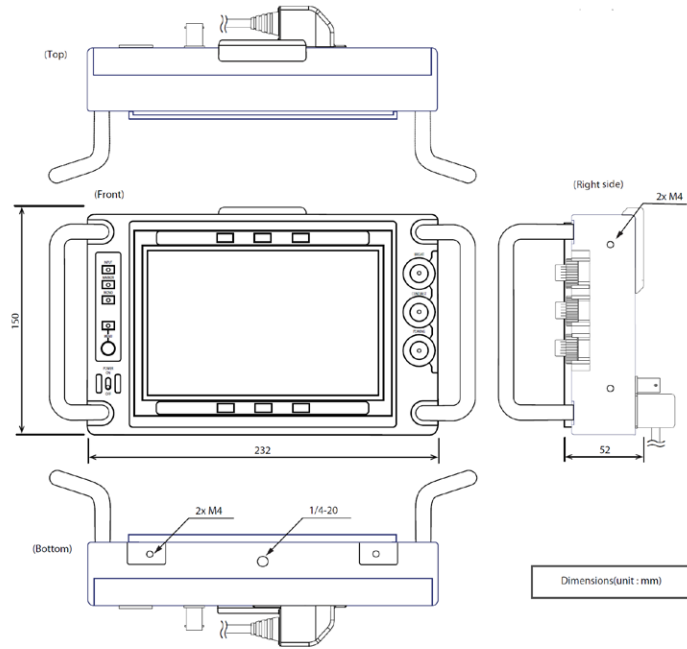

## Robust Mounting Bracket

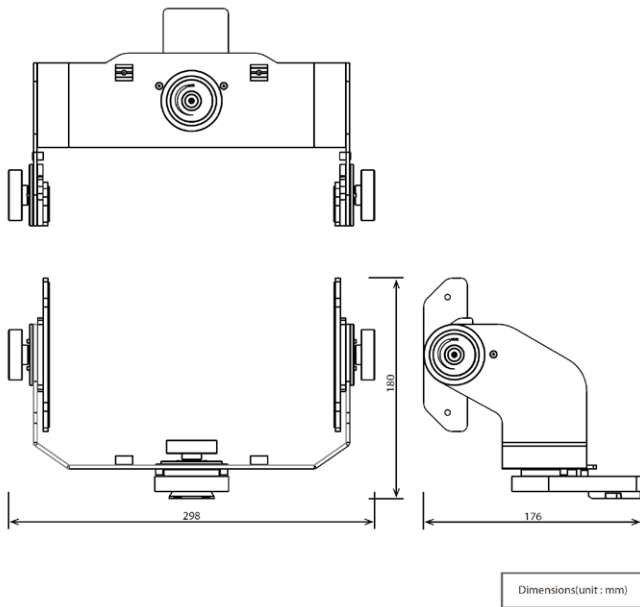

## Articulated Mounting Bracket

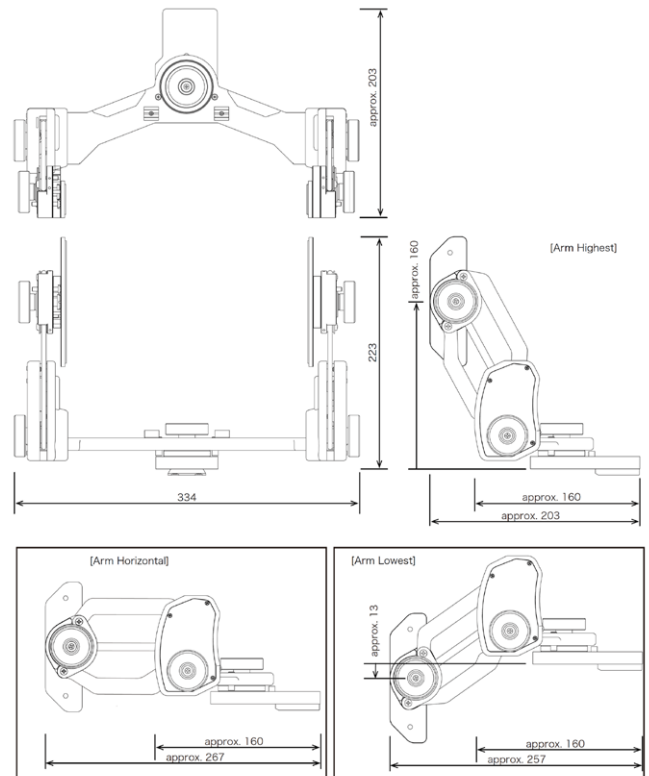

This product may be protected by one or more patents. For further information, please visit: [www.grassvalley.com/patents](http://www.grassvalley.com/patents)

DS-PUB-3-0900H-EN

Grass Valley®, GV®, GV Grass Valley®, and the Grass Valley logo are trademarks or registered trademarks of Grass Valley USA, LLC, or its affiliated companies in the United States and/or other jurisdictions. Grass Valley products listed above are trademarks or registered trademarks of Grass Valley USA, LLC or its affiliated companies, and other parties may also have trademark rights in other terms used herein. Copyright © 2020-2024 Grass Valley Canada. All rights reserved. Specifications subject to change without notice.

[www.grassvalley.com](http://www.grassvalley.com) Join the Conversation at GrassValleyLive on [Facebook](#), [X](#), [YouTube](#) and Grass Valley on [LinkedIn](#)